

Non-Contact Position Sensor

Key Features

- Non-Contact
- Dual channel output allows monitoring of two moving parts with one sensor
- No moving sensor parts
- Up to 90° rotary measurement
- Linear measurement
- Analogue Output
- Unlimited Mechanical Life
- Submersible

The Dual Cavity Sensor accurately and repeatably senses the linear or rotary position of a metallic 'activator' which is mounted to (or formed as part of) the sensed assembly. The activator moves within the two sensor cavities, and an output is produced relative to its position. Different output characteristics can be achieved by varying the activator shape and material. The unique non-contact two-part design utilises Gill's patented inductive technology to provide a reliable, accurate output that will not deteriorate through use.

Small, light and robust, the sensor is simple to install and three different wiring options allow for a multitude of mounting configurations. Sealed to IP67, this sensor is ideal for a variety of applications where grime, moisture, temperature and vibration can have an adverse affect on other types of sensor.



Electrical

Supply Voltage	+6 VDC to +30 VDC
Over Voltage Protection	>31 VDC
Supply Current	<10mA
Reverse Polarity Protection	to -30 VDC
Resolution	10 bit
Sample Rate	1KHz

Analogue Output

Measuring Range	Linear: range governed by activator shape Rotary: ±45°
Output Range (channel 1)	0-4.2 V
Range Accuracy	±3% over full temperature range

Mechanical

Size	19 x 25.5 x 64mm (DxWxL)
Mounting	2 x Ø4mm holes on a 30mm pitch
Weight	34g
Activator Materials	See notes overleaf
Materials Compatibility	Water, engine oil, engine coolant, diesel fuel, gasoline, salt spray, degreaser, degreaser tsp, ammonia and dust. All common automotive liquids and materials

Environmental

Protection Class	IP67
Operational Temperature	-40°C to +85°C (standard)
Storage Temperature	-40°C to +85°C
Dither Life	Non-contact: no deterioration through use

Options

Wiring	- Top exit flying lead - Rear exit flying lead - Integral AMP connector
Output	- Single analogue - Single 5V ratiometric - Dual analogue

Activator Options

- Tinned steel
- EN3B painted mild steel or similar
- Plastic/Copper Foil
- Others compatible, contact Gill with your requirement.

Wiring

	Red	+6VDC to +30VDC Supply
	Black	System & Power Ground (GND)
	Yellow	Analogue Output

Single Output Options

- Integrated AMP Connector 1356-10-021
- 0.5m Flying lead (top exit) 1356-10-022
- 0.5m Flying lead (rear exit) 1356-10-023

5V Ratiometric Sensor Options

- Integrated Connector 1356-10-051
- 0.5m Flying lead (top exit) 1356-10-052
- 0.5m Flying lead (rear exit) 1356-10-053

Dual Output Options

- 0.2m Flying lead (top exit) 1356-10-062

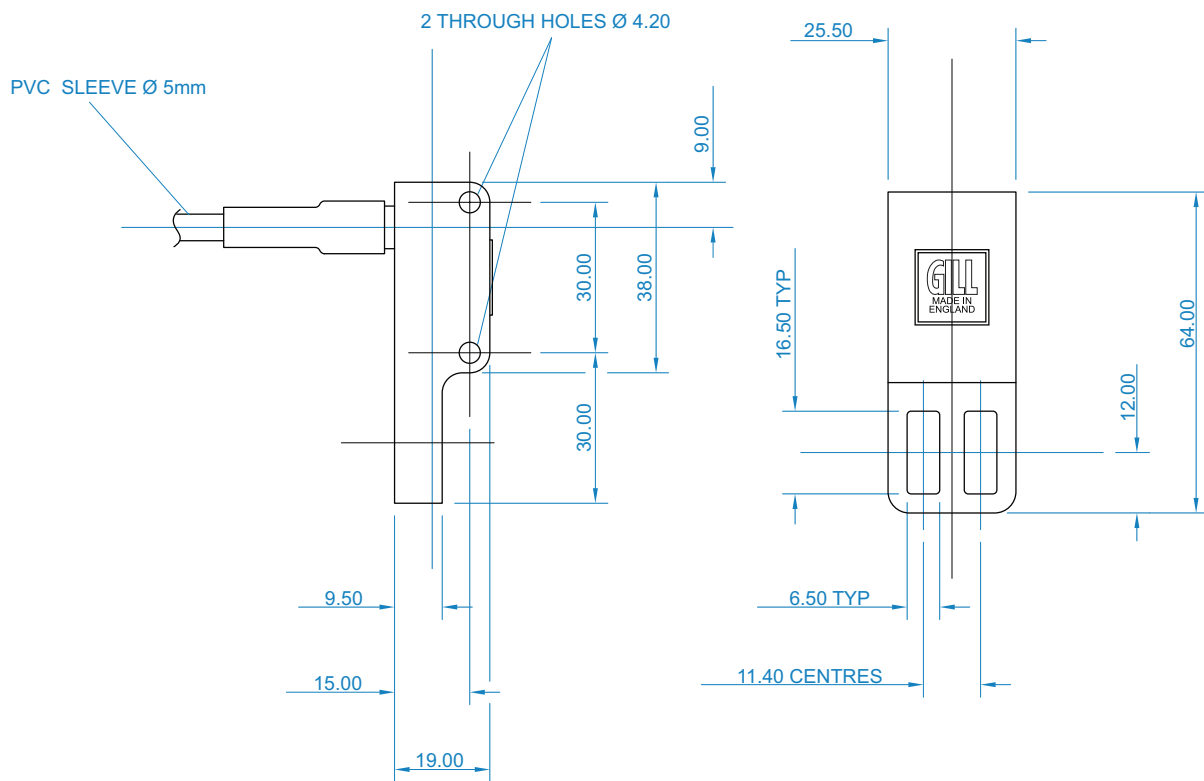

Model shown
Part no: 1356-10-022

All dimensions in mm



Gill Sensors
Saltmarsh Park
67 Gosport Street
Lymington
Hampshire
SO41 9EG, UK

T: +44 (0) 1590 613 400
F: +44 (0) 1590 613 401
E: info@gillsensors.co.uk

www.gillsensors.co.uk

